

COPAL ELECTRONICS

For high vacuum pressure
Thin film type semiconductor pressure gauge

PG-20

CE marking
(Compliance with EMC Standards)

Instruction Manual Ver.1.0

Thank you for purchasing a NIDEC COPAL ELECTRONICS CORP. product.

In order to use the product correctly and most appropriately, please completely read this manual before use and keep it for future reference.

For more detailed information please ask for the nearest distributor or the following sales center.

COPAL ELECTRONICS

Nishi-Shinjuku Kimuraya Bidg., 7-5-25
Nishi-Shinjuku Shinjuku-ku Tokyo 160-0023, Japan Phone. : (03) 3364-7055

Important Information and Warnings



...This caution mark describes when there is a possibility that user may suffer from damage or physical damage may occur if the product is used improperly.

- ① The applicable pressure medium of PG-20 gases and liquids compatible to SUS316L.
- ② For stability, use a regulated direct current power supply.
Please earth the terminal FG when you use the switching power supply.
- ③ Surge absorbing devices (diodes, varistors, etc.) are necessary if inductive loads such as relays or solenoids are connected to the same circuit to PG-20.
- ④ Turn off the power while wiring. Also, please do not mis-wire.
- ⑤ Do not wire parallel to a high tension cables or power lines, or use cable ducts containing high tension or high power.
- ⑥ Cables connectors should be removed from the product while piping. The product can be damaged if the connected cable is pulled at 20N or more. In addition, the display rotation part can be damaged when turning the display at 0.3N·m or more.
- ⑦ Clean the product with the cloth that contains a small amount of pure water or alcohols solvent when the product is dirty. The cleaning solution must never enter into the product. It may cause an internal circuit breakdown.
- ⑧ This product is dust proof and drip proof (to IP40 of IEC standards) and is not suitable for use in environments requiring higher standards.
- ⑨ Do not use pointed objects such as pens to press the setting buttons on the display panel, as this may push holes in the setting buttons and damage them.
- ⑩ Do not insert wires, etc. in the pressure port, as this may damage the internal diaphragm and cause malfunctioning.
- ⑪ Do not touch or scratch the edge of the fitting, as this may damage the sealing and cause leakage.
- ⑫ The PG-20 series is not explosion proof. Do not use it for the detection of flammable gases.
- ⑬ When analog output is supplied to a noise-sensitive device, a low-pass filter is requested in a customer's circuit.
- ⑭ For EMC measures, please earth the power supply. Also, please connect the fitting block to an earthed metallic casing or to the ground. This product can not resist thunder surge, therefore please do not use this product at unprotected outdoors or extend the cable to 30m or more.

Specifications

Spec item	Mode	PG-20	
	Pressure Range	502G/502R	103G/103R
Pressure	Type	Gauge pressure	
	Rated pressure range	0.5MPa	1.0MPa
	Maximum pressure	0.75MPa	1.5MPa
	Vacuum pressure	1.4×10 ⁻⁴ Pa abs maximum	
	Leakage	5×10 ⁻¹² Pa · m ³ / sec maximum (He Leake)	
	Acceptable medium	Gases and Liquids	
Power supply	Operating voltage	24VDC±10% (Current output type) / 12~24VDC±10% (Voltage output type and other)	
	Current consumption	30mA maximum (It doesn't contain switch/analog output.)	
	Insulation resistance	DC125V, 50MΩ minimum/Between bundled electrical wirings and the pressure port.	
	Dielectric strength	DC125V 1minuts (current leakage: 5mA max.) /Between bundled electrical wirings and the pressure port.	
Pressure display	Display method	3 · 1/2 LED display (Red LED)	
	Rotation angle	270° (90° step)	
	Display accuracy	±1%FS (The repeatability, Linality, and Hysteres are contained.)	
	Thermal error	±0.1%FS/°C (0~50°C, reference temperature at 25°C.)	
	Response	4 times/sec	
	Switch output	Number of circuits	Select model (N.A/One circuit (SW1) /Two circuits (SW1, SW2))
Output method		Select model (NPN/PNP, transistor open collector)	
SW capacity		30VDC at 100mA minimum	
Residual voltage		1.2V (NPN)/2.2V (PNP) maximum at Load current (100mA)	
Hysteresis		0~300counts (Can be ajusted)	
Operation display		Green LED lights with switch ON.	
Protection function		None	
Repeatability		±0.3%FS maximum	
Thermal error		±0.1%FS/°C (0~50°C, reference temperature at 25°C.)	
Response		Can be adjusted to Approx. 2.5ms/25ms/250ms	
Analog output		Number of circuits	Select model (N.A/One circuit (White lead line:Vo /Ao))
	Output method	Select model (Voltage output: 1-5V/Current output: 4-20mA)	
	Range of output	Select model (G: Positive pressure range/R: Compound pressure range)	
	Output mode: (G/R)	(G) 0.0~0.5MPa, (R) -0.1~0.5MPa	(G) 0.0~1.0MPa, (R) -0.1~1.0MPa
	Vzero/zero	(G) 1.00V/4.00mA, (R) 1.67V/6.67mA	(G) 1.00V/4.00mA, (R) 1.36V/5.46mA
	Vfull/full	(G/R) 5.00V/20.00mA	(G/R) 5.00V/20.00mA
	Output accuracy	±1%FS by load resistance (Voltage output type: 1MΩminimum/Current output type: 250Ω)	
	Thermal error	±0.1%FS/°C (0~50°C, reference temperature at 25°C.)	
Response	1m s maximum		
Pressure contact	Fitting	Select model (W1: 1.5"W-Seal/W2: 1.125"W-Seal)	
	Sensor material	SUS316L	
	Fitting material	SUS316L	
	Roughness	Ra:0.15μm (Ave.) / Ry:0.7μm (Max.)	
	Particle	Zero count for size 0.1 μm or greater (by our inspection standard)	
Use conditions	Operating temp.	-10~50°C (No condensation)	
	Operation humidity	35~85%RH (No condensation)	
	Storage temp.	-20~60°C (No condensation)	
Environment characteristics	Vibration resistance	10~500Hz 1.5mm max./98.1m/s ² 3 directions, 2 hours each	
	Shock	490m/s ² 3 directions, 3 times each	
	High temp.	70°C 96 hours, No load	
	Low temp.	-20°C 96 hours, No load	
	Humidity	40°C 90~95%RH 240 hours, No load	
	Pressure cycle	0~Rated pressure range 10 ⁵ cycles, No load	
	EMC	EMC directive: 2004/108/EC Applicable standards: EN61326-1: 2006, EN61326-2-3: 2006 (EMI: Class B, EMS: Annex BB)	
Others	IP protection	Close type structure (EC standard: P40)	
	Connected method	Connector type (HG connector from JST)	
	Net Weight	W1: Approx. 200g W2: Approx. 110g (Only the main body)	
	Accessories	Manual, Cable (2m) , Cable holder	

Output Electrical Diagram (Example: PG-20-103R- * * W2)

(■-B: Display single function type is omitted)

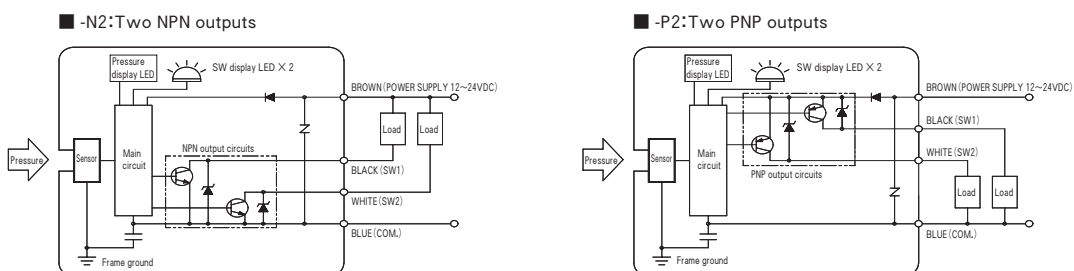

■ -NV:One NPN output and voltage output

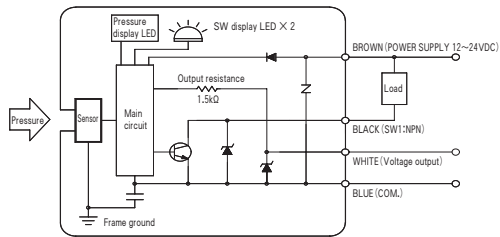

■ -PV:One PNP output and voltage output

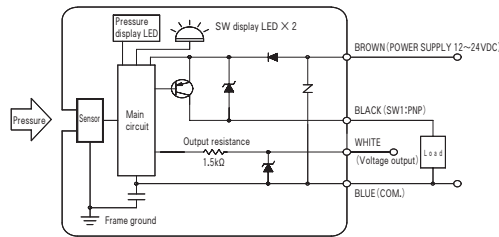

■ -NA:One NPN output and current output

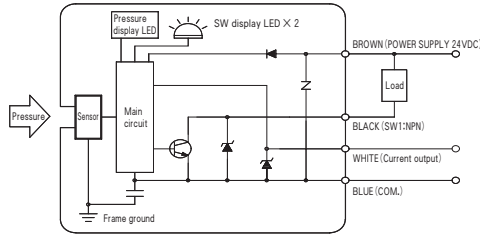

■ -PA:One PNP output and current output

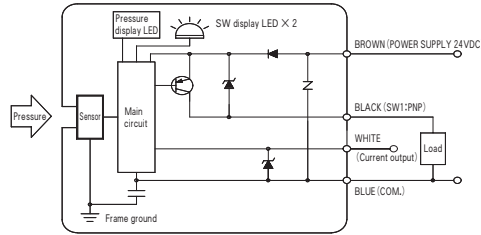

Terminal wiring list

Model	(ex.) PG-20-103R-**-W2			
Lead	-BW2	-(N/P)2W2	-(N/P)VW2	-(N/P)AW2
Brown	Power supply: (12~24VDC±10%)		(24VDC±10%)	
Black	N. C.	Switch output:SW1 (NPN/PNP)		
White	N. C.	Switch output SW2 (NPN/PNP)	Voltage output (1~5V)	Current output (4~20mA)
Blue	COMMON			

Panel function explanation

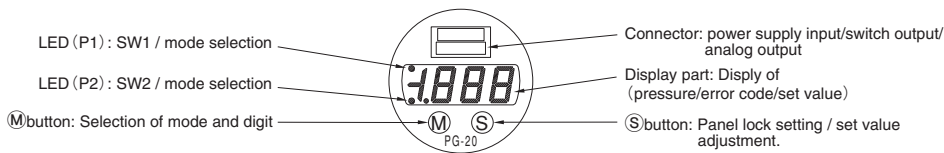

Initial operation

◆Initial Operation



1. All displays will light for one second after initial operation.
2. Pressure display and SW will be in operation.
3. The panel lock will be turned on at the initial operation due to setting protection.

Operating procedure

◆Release panel lock.

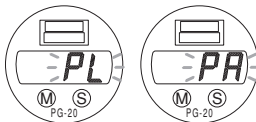

1. After the initial operation, you must turn off the panel lock in order to adjust the setting.
2. The panel lock can be released by pushing the S button until the blinking LED turns from "PL" to "PA".

◆Switch of mode

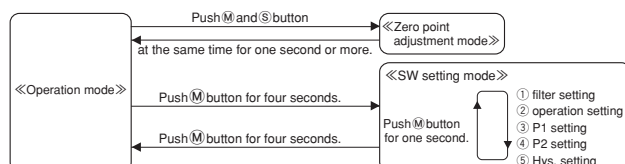

Zero point adjustment

Pressure display can be adjusted to Zero at Open pressure port. However, the analog output can not be zero adjusted.

◆Adjust Zero points



1. Release the pressure port to an atmospheric pressure.
2. Zero point adjustment starts when **M** and **S** button are pushed at the same time for one second or more at the operation mode. Display will read "0A" when Zero point adjusting.

◆Finish Zero point adjustment



1. Release the **M** and **S** button when "0A" is displayed.
2. Zero points will be adjusted in one second, and will return to operation mode.
3. Zero points will be memorized, and will not be lost even if the power is turned off.



1. "E2" blinks when there is the remaining pressure.
2. Please push either of the button to go back to the operation mode. Please pushing the button of either.
3. Release the pressure port to an atmospheric pressure and adjust the zero point again.

Switch setting mode

Adjustment of filter setting, switch operation, pressure switch (P1/P2), and hysteresis.

◆Filter Setting

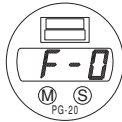

1. Push the **M** button for four seconds or more at operation mode.
2. After entering the switch setting mode, the display will blink once at present set value. Factory default for filter setting is set at "F-0".
3. The setting value can be adjusted from "F-0" to "F-2" by pressing the **S** button. Filter: ("F-0": 2.5ms, "F-1": 25ms, "F-2": 250ms) After the value is set for filter, the filter will be in effect by displaying the average pressure at given filter setting.

★When **M** button is pushed for one second or more, it will move the next setting mode. If the **M** button is pushed for another one second or more, it will exit for switch setting mode and return to operation mode.

(Omit)

☆If there is no switch mode for your model, the following setting model shall not apply.

◆Switch operation setting



However, it displays it in the product with only SW1 in order of S-1/S-3/C-5/C-7.

1. In the SW operation setting mode, the blinking display ..present set value.. is done once.
2. It displays in order of "S-1" to "S-4" and "C-5" to "C-8" whenever **S** button is pushed short, and this is repeated.

However, it displays it in the product with only SW1 in order of "S-1/S-3/C-5/C-7".

S:Separate mode, C: Window comparator mode. Factory default is set at "S-1"

★Ditto

Value selected	Output	SW1 output				SW2 output			
	Mode	Separate		Window comparator		Separate		Window comparator	
	Operation	H	L	A	B	H	L	A	B
S-1		○				○			
S-2		○					○		
S-3			○				○		
S-4			○				○		
C-5				○				○	
C-6				○				○	
C-7					○				○
C-8					○				○
		P 1		Minimum: P 1 Maximum: P 2		P 2		Minimum: P 1 Maximum: P 2	
		Note 1		Note 2		Note 1		Note 2	

Note 1. In Separate mode, P1 corresponds to SW1, and P2 corresponds to SW2.

Note 2. In the window comparator mode, common lower bound value corresponds to P1 and upper bound value corresponds to P2.

Note 3. Hysteresis (H) is a common setting to SW1/SW2 and the operation mode.

There are four operation modes. These are shown in the diagrams below.

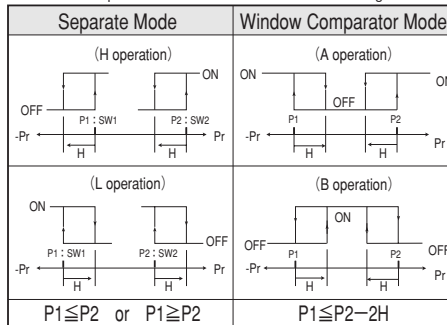

◆Pressure switch P1 setting.



1. In the Pressure SW setting mode, the display will blink once at present set value. P1 setting starts when the P1 display LED on the top left blinks. (P1: SW1 setting value of separates mode or lower bound value of window comparator)
The factory default is set at "500"

2. The digit that is blinking can be adjusted.

S button is pressed to increment the blinking value.

3. Blinking digit can be adjusted by pressing the **M** button.

The very top digit can only be adjusted in the following value: +1/-1/-0/+0.

★Ditto

For Separate mode setting with 1 Switch output model, P2 setting is not needed and will jump directly to hysteresis setting mode.

◆Pressure switch P2 setting



1. In the Pressure SW setting mode, the display will blink once at present set value. P2 setting starts when the P2 display LED on the bottom left blinks. (P1: SW1 setting value of separates mode or lower bound value of window comparator)
The factory default is set at ".500"
2. The digit that is blinking can be adjusted.
Ⓢ button is pressed to increment the blinking value.
3. Blinking digit can be adjusted by pressing the Ⓜ button.
The very top digit can only be adjusted in the following value: +1/-1/-0/+0.
★Ditto

◆Hysteresis setting



1. In the hysteresis setting mode, the display will blink once at present set value. Hysteresis setting starts when P1 and P2 display LED of the left side blink.
Hysteresis: Common hysteresis value for switch. The factory default is set at ".020"
 2. The digit that is blinking can be adjusted.
Ⓢ button is pressed to increment the blinking value.
 3. Blinking digit can be adjusted by pressing the Ⓜ button.
Hysteresis can be adjusted from ".000" to ".300"
- ★By pressing the Ⓜ button for one or more seconds, it will return to filter setting. Ditto.

Setting protection function (panel lock)

◆About panel lock

- This function limits the panel operation so that each setting condition is not changed by mistake.
- In the state of the panel lock, when a button is operated, "PL" is blinked several times.
And zero point adjustment and the switch setting, etc. can not be adjusted.
- The panel lock can be released by the following operation. However, panel lock will be set at the initial operation. when starting again.

◆Release/set of panel lock

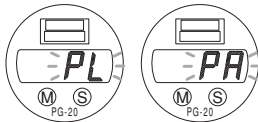

1. When the panel lock is set, push the Ⓢ button for four seconds or more until the display blinks. Display will change from "PL" into "PA", when the panel lock is released.
2. When the panel lock is relased, push the Ⓢ button for four seconds or more until the display blinks. Display will change from "PA" into "PL", when the panel lock is set. After the panel ock is set, the display will return to operation mode.

Troubleshooting

◆Action when following error messages display.



Error message/trouble	Problem	Solution
"E2"	Pressure detected when adjusting the zero point.	Please release the error display pushing either button, and adjust Zero again.
"E3"	It doesn't satisfy the pressure setting of window comparator mode.	Please release the error display. And, try to set pressure SW.
"E4"	The memory data is abnormal.	Please contact the nearest sales office.
"-H-"	The range of detection is exceeded.	This is not an error. Product is operating normally.
LED doesn't light all	LED might have broken down.	Please contact the nearest sales office.
Panel not in operation	The panel lock is set.	Please review the instruction for panel lock setting.
P2 cannot be set	P2 of separates mode cannot be set.	The is only one switch for this model.

Externals specification (unit : mm)

◆PG-20 externals dimensions / Example of accessory usage

PG-20-***R/G-***W1

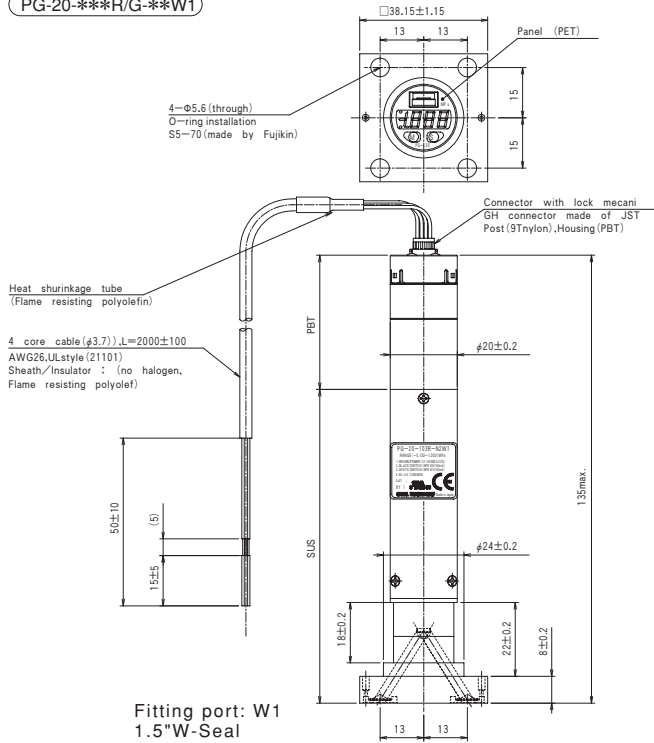

PG-20-***R/G-***W2

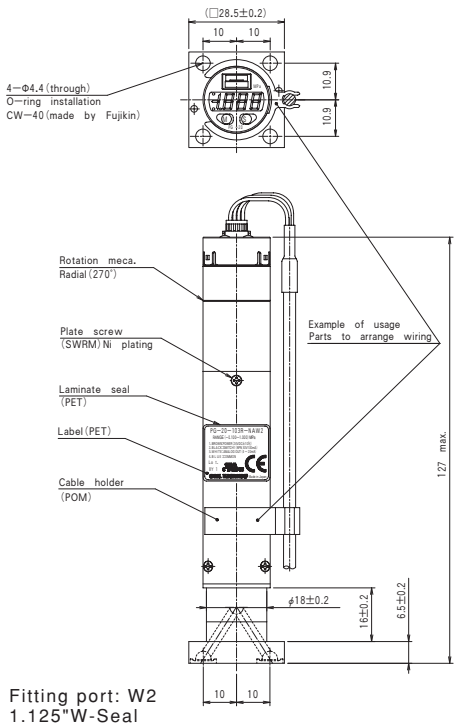

Warranty

NIDEC COPAL ELECTRONICS warrants the product for period of 1.5 years after the date of the customer's receipt. We will repair the troubled products caused by our improper designing and/or production control at our cost. Our warranty is limited to the products only, not on another damage that is caused by the product malfunction. However, following cases will not be applicable for the warranty.

- ①. Breakdown/damage due to carelessness in wrong use and use to manual
- ②. Breakdown/damage because of improper processing/adjustment/repair
- ③. Breakdown/damage by natural disaster/fire/other inevitability

Model

PG-20-103 R-NV W1

① ② ③ ④

- ① Pressure range 502 : Pr (0.500MPa)
103 : Pr (1.000MPa)
- ② Indicating type G : Gage pressure (positive) 0MPa~Pr ※
(Analog output range) R : Gage pressure (compound) -0.1MPa~Pr ※
- ③ Output spec. B : SW (nothing)
* (N: NPN/P: PNP) *2 : SW (two outputs)
*V : SW (one output) +Voltage output (1~5V)
*A : SW (one output) +Current output (4~20mA)
- ④ Fitting block spec W1 : 1.5"W-Seal
W2 : 1.125"W-Seal

※ Please choose (R) in the indicating type when the analog output is unnecessary.



SCIGATE AUTOMATION (S) PTE LTD
 No.1 Bukit Batok Street 22 #01-01 Singapore 659592
 Tel: (65) 6561 0488 Fax: (65) 6562 0588
 Email: sales@scigate.com.sg Web: www.scigate.com.sg
 Business Hours: Monday - Friday 8.30am - 6.15pm